

Technical Documentation

Constant flow rate control / shut-off unit type VRW-A



LTG Aktiengesellschaft

70435 Stuttgart, Grenzstraße 7, Germany
Tel. +49 711 8201-0, Fax +49 711 8201-720
info@LTG-AG.com
www.LTG-AG.com

LTG Incorporated

105 Corporate Drive, Suite E
Spartanburg S.C. 29303, USA
Tel. +1 864 599-6340, Fax +1 864 599-6344
info@LTG-INC.net
www.LTG-INC.net

LTG S.r.l. con socio unico

Via Matilde Serao 5, 20144 Milano (MI), Italy
Tel. +39 02 9550535, Fax +39 02 9550828
info@LTG-SRL.it
www.LTG-SRL.com

Constant flow rate control and shut-off unit type VRW-A

Notes

Dimensions stated in this brochure are in mm.

Dimensions stated in this brochure are subject to General Tolerances according to DIN ISO 2768-vL.

Straightness and twist tolerances according to DIN EN 12020-2.

The actual specifications are at the end of this document. They are available as a word document at your local distributor or at www.LTG-AG.com.

Constant flow rate control and shut-off unit type VRW-A

The constant flow rate control and shut-off unit type VRW-A is the combination of a mechanically self-operated constant flow rate controller and a shut-off damper.

Unit view

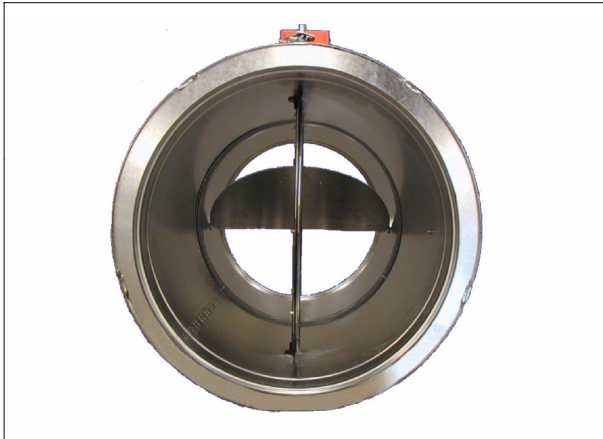

Figure: Interior view

Function

Flow control is obtained through an asymmetrically angled regulating blade on friction-free bearings, ensuring precision response and regulating action even with small flow rates.

The flow rate may be changed by modifying the preload of a tension spring via an adjusting device with a flow scale.

Since a mechanically self-operated flow rate controller has no shut-off function because of the spring between the adjusting device and the damper, the compact unit VRW-A has been combined with a separate shut-off damper.

Advantages

- Lower installation cost by using two compact units. Two components in one, factory pre-assembled.
- The balanced damper blade allows for an installation in any duct orientation.
- A pneumatic metal piston damper prevents the regulating plate from oscillating.
- A very short straight entry flow duct is required.
- The controllers are insensitive to dust or temperature-related effects.
- No rivets or bolts are required for a horizontal installation (using the self seal system).
- Due to the self sealing system, the components may be removed very easily from the duct system without the need of any tools.
- The controller components are ageing and temperature resistant in a range of -15 °C ... +100 °C.

Design, characteristics

The duct casings are made from hot galvanized sheet steel. The flow rate controller and the shut-off damper assemblies are supplied as one piece with suitable sealing. For the shut off damper, there is an oval damper blade of galvanized sheet steel sealed with a felt gasket as standard (or polymer seal to DIN 1946/4 using EPDM). The damper is positioned on a round galvanized precision steel shaft meeting DIN 1652 requirements. An angle scale on the housing simultaneously serves as a position indicator. The shaft is maintenance-free and low-friction due to the use of copolymer bearing bushings (Hostaform C 9021).

Snap-in rubber seal system on the flow rate controller's outflow side: Components are easily installed by simply inserting the plug-in ends into the duct (a procedure during which a round, roll-off sealing ring is pressed axially and radially against the tube wall to finally snap in a specific groove). No screws or rivets are needed for further fixation. This sealing method meets tightness class 4 requirements. On the damper blade's inflow side a twin lip sealing gasket with similar features is used.

Installation

Positioning the shut-off damper in direction of the airflow in front of the flow rate controller naturally provides a straight entry distance of 1-2 equivalent duct diameters, depending on the model size.

If the entry conditions are very unfavourable the following straight entry distances should be observed:

- 0.5 x D for DN 100-140;
- 1 x D for DN 160-250;
- 1.5 x D from DN 315.

There are no restrictions, however, regarding the outflow side.

Accessories, special versions

- 50 mm insulated case
- Shut-off damper leakproof according to DIN 1946/4 (except DN 140)
- Flexible sound absorber SDE-AO of corrugated aluminium tube
- Rigid sound absorber SDE-SO, as above, with galvanized sheet steel jacket
- Shut-off damper actuators of any well known manufacturer

Other versions on request.

Constant flow rate control and shut-off unit type VRW-A

Flow rate and pressure range

Size NW	Surface [m ²]	V _{min} [m ³ /h]	V _{max} [m ³ /h]	Δp _{min} [Pa]	Δp _{max} [Pa]
100	0.008	70	200	50	1000
125	0.012	100	280		
140	0.015	140	400		
160	0.020	180	500		
200	0.031	250	900		
250	0.048	500	1500		
315	0.077	800	3000		
400	0.124	1000	4500		

Legend

Size NW	Nominal diameter
V_{min}	Minimum flow rate
V_{max}	Maximum flow rate
Δp_{min}	Minimum pressure loss
Δp_{max}	Maximum pressure loss

Minimum pressure loss

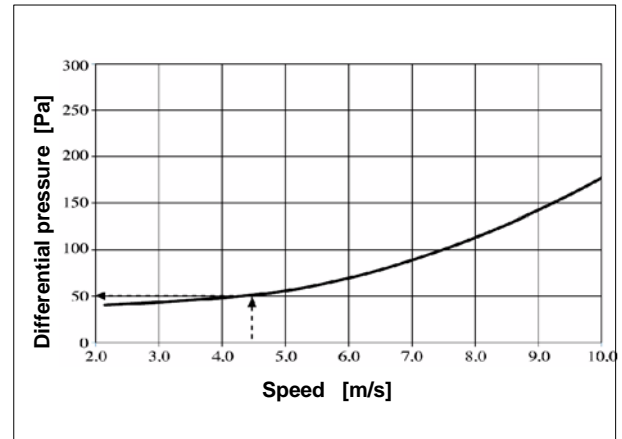

Example:

Flow rate controller:	Type VRW-A
Nominal diameter:	NW 160
Air speed:	4.5 m/s
Flow rate:	325 m ³ /h

Minimum static pressure difference Δp according to chart:

50 Pa

Constant flow rate control and shut-off unit type VRW-A

Dimensions and weights

Size NW	D [mm]	D ₁ [mm]	L [mm]	L ₁ [mm]	L ₂ [mm]	H [mm]	H ₁ [mm]	M [mm]	N [mm]	Damper angle [°]	Weight [kg]	
											without insulated case	with insulated case
100	99	199	435	40	40	190	265	105	140	60	2.1	4.4
125	124	224	435	40	40	215	290	105	140	60	2.4	6.4
140	139	239	435	40	40	230	305	125	140	60	2.9	7.5
160	159	259	525	40	40	250	325	125	180	60	3.2	8.8
200	199	299	525	40	40	290	365	125	180	60	4.4	10.3
250	249	349	590	60	40	340	415	190	180	60	5.8	13.3
315	314	414	590	60	60	405	480	190	180	60	9.4	17.3
400	399	499	740	80	60	490	565	238	220	60	13.6	26.2

Version without insulated case, including Belimo NM .. actuator

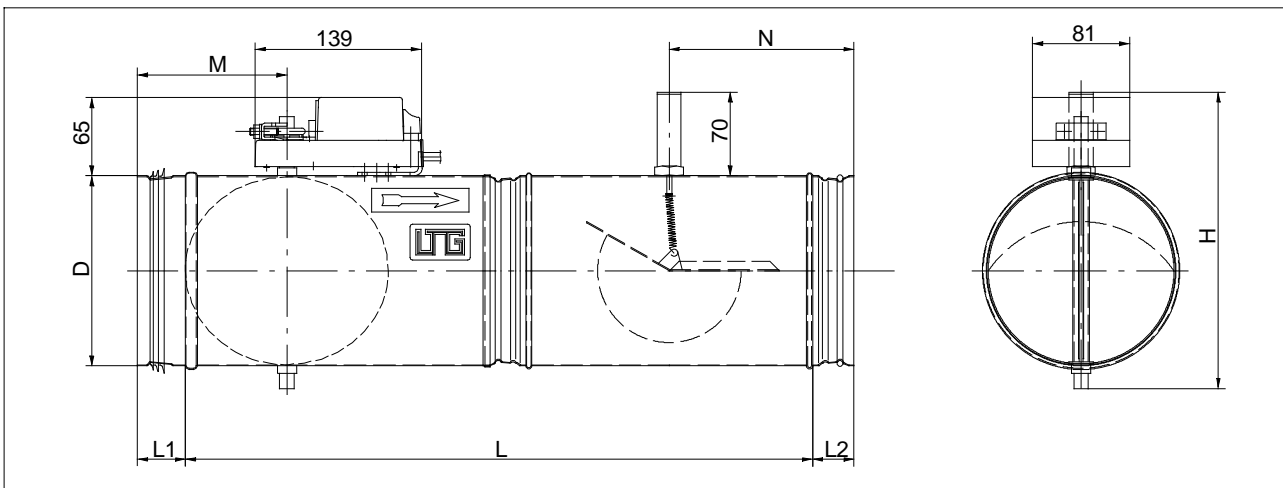

Version with insulated case, including Belimo NM .. actuator

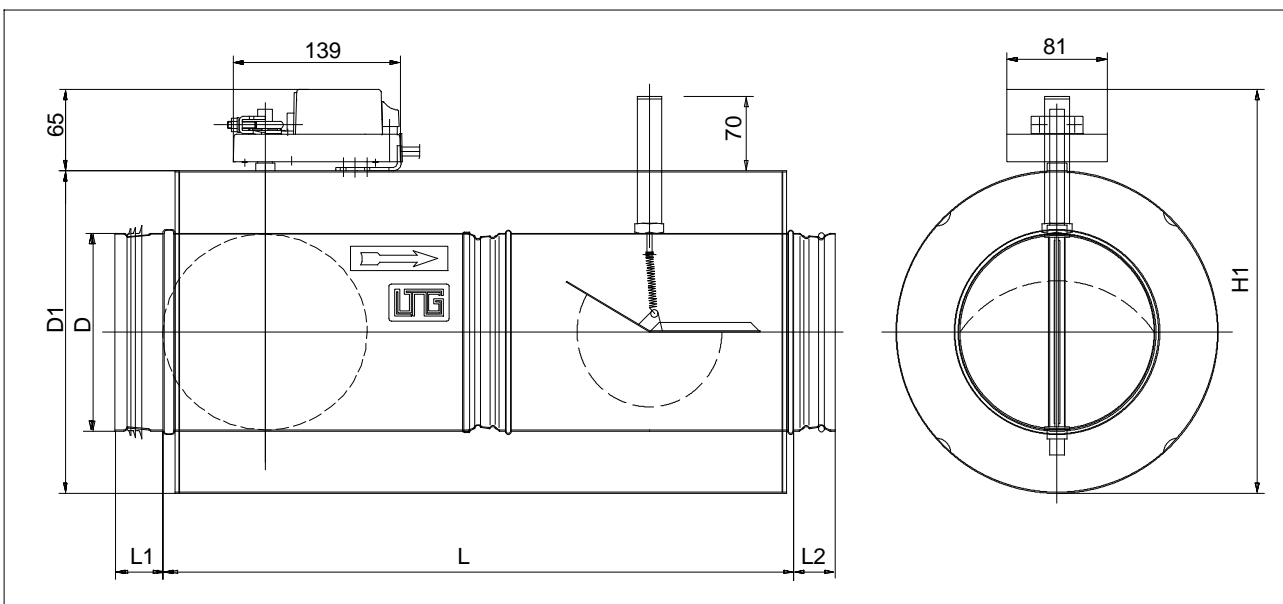

Constant flow rate control and shut-off unit type VRW-A

Airborne sound transmission

Nominal diameter [mm]	Flow rate [m ³ /h]	Static pressure difference at the controller [Pa]																										
		100 [Pa]								250 [Pa]								500 [Pa]										
		Octave power level* L _W [dB/Oktave]								Octave power level* L _W [dB/Oktave]								Octave power level* L _W [dB/Oktave]										
		63 Hz	125 Hz	250 Hz	500 Hz	1000 Hz	2000 Hz	4000 Hz	8000 Hz	Power level L _{Wtot} A-weighted [dB(A)]	63 Hz	125 Hz	250 Hz	500 Hz	1000 Hz	2000 Hz	4000 Hz	8000 Hz	Power level L _{Wtot} A-weighted [dB(A)]	63 Hz	125 Hz	250 Hz	500 Hz	1000 Hz	2000 Hz	4000 Hz	8000 Hz	Power level L _{Wtot} A-weighted [dB(A)]
100	70	40	39	38	36	35	36	30	29	41	43	45	46	46	47	49	44	43	53	49	52	52	53	54	55	50	50	60
	135	50	48	45	42	41	40	34	33	46	59	57	54	51	50	49	43	42	55	60	60	58	57	57	58	53	52	63
	200	54	52	49	47	45	45	39	38	51	63	61	58	55	54	54	48	47	59	70	68	65	62	61	60	54	53	66
125	100	41	40	38	36	35	36	30	29	41	45	47	47	48	48	49	44	43	54	52	54	54	54	55	56	50	49	60
	190	51	49	46	42	41	40	34	32	46	55	54	53	51	51	51	46	45	56	61	61	59	58	57	58	52	52	63
	280	54	53	50	47	45	45	39	37	50	63	61	58	55	54	53	47	46	59	64	64	62	61	61	62	57	56	67
140	140	43	42	40	38	37	37	31	30	42	47	49	49	49	50	51	46	45	55	53	56	56	56	56	58	52	51	62
	270	53	51	47	44	43	42	36	34	48	61	59	56	53	51	51	44	43	57	63	63	61	60	59	60	54	54	65
	400	56	55	52	49	47	47	41	39	52	65	63	60	57	56	55	49	48	61	72	70	67	64	62	62	56	55	68
160	180	44	43	41	39	38	38	32	31	43	48	50	50	50	50	51	46	45	56	55	57	57	57	57	58	53	51	63
	340	53	51	48	44	43	42	36	34	48	62	60	56	53	51	51	44	43	57	64	64	62	60	60	60	55	54	65
	500	57	55	52	49	47	47	40	39	52	66	64	61	58	56	55	49	48	61	72	70	67	64	62	62	56	54	68
200	250	45	43	41	39	38	37	31	30	43	51	52	52	51	51	51	45	44	56	57	59	58	58	57	58	52	50	63
	575	55	53	50	46	44	44	37	36	50	64	62	58	55	53	53	46	45	59	66	66	64	62	62	62	56	56	67
	900	-	-	-	-	-	-	-	-	-	68	66	63	60	58	58	52	50	64	75	73	70	67	65	65	58	57	70
250	500	48	47	45	43	41	41	35	34	47	54	56	55	55	54	55	49	48	60	61	62	62	61	61	62	56	54	66
	1000	57	55	52	49	47	46	39	38	52	66	64	61	57	55	55	48	47	61	69	68	67	65	64	64	59	58	69
	1500	-	-	-	-	-	-	-	-	-	70	68	65	62	60	60	53	52	65	77	75	72	68	67	66	60	58	72
315	600	48	46	44	41	39	39	32	31	44	55	56	55	54	53	53	46	44	58	62	63	62	61	60	59	53	51	65
	1400	57	55	52	48	46	45	39	37	51	66	64	60	57	55	54	47	46	60	70	69	67	65	64	64	58	57	69
	2200	-	-	-	-	-	-	-	-	-	71	69	65	62	60	59	53	51	65	77	75	72	69	67	66	60	58	72
400	100	50	48	45	42	41	40	33	31	46	58	59	57	56	55	54	47	45	59	65	65	64	62	61	61	54	51	66
	2200	58	56	52	49	47	46	39	37	52	67	65	61	57	55	54	48	46	61	72	71	68	66	65	65	59	57	70
	3800	-	-	-	-	-	-	-	-	-	73	71	67	64	62	61	55	53	67	79	77	74	70	68	68	61	60	74

*Sound power level in dB/octave ref to 10⁻¹² W

The flow rate controller's sound power may be increased in case of additional sound sources (e.g. fan, unfavourable flow conditions etc.). If this additional sound power level is more than 10 dB below the sound power level of the flow rate controller, it may be neglected. The A-weighted sound power level (airborne sound transmission L_{WtotA}) does not include the duct outlet and room absorption.

The room and outlet absorption may be calculated, but is generally around 8 dB. In order not to exceed the required sound pressure level of a room, installation of a suitably selected absorptive silencer between the flow rate controller and the room or insulation of the duct system is desirable.

Casing radiation depends on local conditions, the emitting duct surface (duct diameter and length) before the sound absorber and the sound insulation. In practice, values obtained in test labs do not necessarily comply with the actual conditions found in a duct system.

Constant flow rate control and shut-off unit type VRW-A

Sound level correction values for sound emission calculation

Deduct the values given in this chart from the "Airborne Sound Transmission" values on page 6.

Nominal diameter [mm]	Duct not insulated									Duct with 50 mm insulation and sheet steel casing								
	L _w [dB]									L _w [dB]								
	f _m [Hz]									f _m [Hz]								
	63	125	250	500	1000	2000	4000	8000	Sum [dB(A)]	63	125	250	500	1000	2000	4000	8000	Sum [dB(A)]
100	34	32	30	22	16	12	11	10	14	41	38	46	45	47	54	57	47	46
125	29	29	31	24	21	19	15	11	18	35	36	42	48	51	60	58	45	38
140	27	28	27	21	18	14	12	10	16	31	30	37	42	45	52	54	44	40
160	23	23	20	18	11	10	9	8	11	29	28	35	40	44	51	54	44	38
200	22	19	16	16	15	11	9	8	13	26	22	29	37	42	51	53	43	33
250	19	16	13	12	12	10	9	8	11	25	20	26	35	41	50	52	42	30
315	18	14	12	13	11	11	8	8	11	26	18	26	38	42	51	53	45	30
400	17	11	10	10	10	9	7	6	9	20	16	23	33	39	48	50	40	26

The acoustic data given include a +/- 3 dB tolerance.

Constant flow rate control and shut-off unit type VRW-A

Nomenclature

		VRW-A	...	/	.	/	.	/
		Mechanically self-operated constant flow rate controller, round, with integrated shut-off damper								
		Size or diameter	100							
			125							
			140							
			160							
			200							
			250							
			315							
			400							
Version	steel, galvanized								S	
	stainless steel V4A (1.4571)								F	
	flow rate controller with PUR finish shut-off damper of V4A (1.4571)									K
	Insulated case	without							-	
		with							D	
		Shut-off damper actuator								LM 24
										NM 24
										LF 24
										AF 24
									

Specification and schedule of prices

Constant flow rate control and shut-off unit type VRW-A

August 2011 / page 1 of 2

Quantity	Description of services	Unit price in €	Total price in €
	<p>Mechanically self-operated constant flow rate controller type VRW without auxiliary power supply, with integrated shut-off device.</p> <p>For any installation type, suitable for differential pressures of 50 ... 1000 Pa, control precision +/- 10%. Suitable for on site change to the factory-set flow rate, using an adjusting ring with a flow rate scale.</p> <p><u>Consisting of:</u></p> <ul style="list-style-type: none"> - <u>Casing</u> of galvanized sheet steel. Connection: self-seal system on the flow rate controller side, lip seal gasket on the shut-off damper side, for insertion in lock-seam wound ducts according to DIN 24145. - Flow rate controller with aluminium <u>regulating blade</u> on friction-free plastic bearings with vibration damper, corrosion-protected, aging resistant and maintenance-free. Operating range: -20 °C ... +100 °C. Shut-off damper tightness in compliance with DIN EN 1751 Class 2. Shut-off damper with oval damper blade of galvanized sheet steel with EPDM seal, tightness in compliance with DIN 1946/4. Form-fitting damper axle of galvanized precision steel in compliance with DIN 1652. Maintenance-free, low-friction damper bearing bushings of plastic (Hostaform C 9021). <p>Sizes, dimensions (D x L):</p> <ul style="list-style-type: none"> o 100, installation length 435 mm o 125, installation length 435 mm o 140, installation length 435 mm o 160, installation length 525 mm o 200, installation length 525 mm o 250, installation length 590 mm o 315, installation length 590 mm o 400, installation length 740 mm <p>Manufacturer: LTG Aktiengesellschaft Series: Constant flow rate controller Type: VRW-A</p> <p>Accessories, special equipment (optional, additional charge):</p> <ul style="list-style-type: none"> o All sheet steel components within the air flow are made of V4A (1.4571) o Flow rate controller with PUR finish, shut-off damper of V4A (1.4571) o 50 mm insulated case, galvanized sheet steel jacketed o Damper actuator Belimo LM24 o Damper actuator Belimo LF24 (spring return motor) o Version with Belimo LM24/NM24 actuator for set-point changeover 		

Constant flow rate control and shut-off unit type VRW-A

Germany

Office East 2

Sales area: **postcode 01 - 09, 98 - 99**
Johannes-Ebert-Straße 20 · D-09128 Chemnitz
Herr Schenfeld ☎ +49 371 77118-01, Fax -02
E-mail: Schenfeld@LTG-AG.de

Office East 1

Sales area: **postcode 10 - 25, 39**
Eisenhutweg 51a · D-12487 Berlin
Herr Linke ☎ +49 30 632287-74, Fax -75
E-mail: Linke@LTG-AG.de

Office North

Sales area: **postcode 20 - 31, 38**
An den Auewiesen 24 · D-31515 Wunstorf
Herr Krockner ☎ +49 5031 5150234, Fax 9623334
E-Mail: Krockner@LTG-AG.de

Office West

Sales area: **postcode 32 - 33, 40 - 53, 58 - 59**
Baststraße 30 · D-46119 Oberhausen/Rheinl.
Herr Perenz ☎ +49 208 30431-55, Fax -56
E-mail: Perenz@LTG-AG.de

Central Office 2

Sales area: **postcode 34 - 37, 56 - 57, 61 - 62, 65**
Sperberweg 16 · D-35745 Herborn
Herr Hartmann ☎ +49 2772 570-725, Fax -727
E-mail: M.Hartmann@LTG-AG.de

Central Office 1

Sales area: **postcode 54 - 55, 60, 63 - 64, 66 - 69, 97**
Wingerstraße 3a · 64390 Erzhausen
Herr Lohr · Tel. +49 6150 542-1868, Fax -1892
Lohr@LTG-AG.de

Office Southwest

Sales area: **postcode 70 - 79, 88 - 89**
Grenzstraße 7 · D-70435 Stuttgart
Frau Schanbacher · Tel. +49 711 8201-181, Fax -210
E-Mail: Schanbacher@LTG-AG.de

Office South

Sales area: **postcode 80 - 87, 90 - 96**
Grenzstraße 7 · D-70435 Stuttgart
Frau Schanbacher · Tel. +49 711 8201-181, Fax -210
E-Mail: Schanbacher@LTG-AG.de

Austria

KTG Klimatechnische Gesellschaft mbH

Schubertstraße 13 · A-2126 Ladendorf
☎ +43 2575 210-89, Fax -22 · E-Mail: office@ktg-wien.com

Great Britain

MAP Motorised Air Products Ltd.

Unit 5A · Sopwith Crescent
Wickford Business Park · Wickford · GB-Essex SS11 8YU
☎ +44 1268 5744-42, Fax -43 · E-Mail: info@mapuk.com

Netherlands

Opticlina Systems b.v.

Leeuwerikstraat 110 · NL-3853 AG Ermelo
☎ +31 341 4939-69, Fax -31 · E-Mail: info@opticlina.nl

Poland

HTK Went Sp.z.o.o.

ul. Chopina 13/3 · PL-30047 Krakow
☎ +48 12 632-3132, Fax -8193 · E-Mail: info@htk-went.pl

Portugal

ArGelo S. A.

R. Luis Pastor de Macedo · Lote 28 B, P-1750-158 Lisboa
☎ +351 21 75201-20, Fax -29 · E-Mail: info@argelo.pt

Switzerland

Laminair AG

Kirchbergstrasse 105 · CH-3400 Burgdorf
☎ +41 34 42002-10, Fax -11 · E-Mail: info@laminair.ch

Turkey

Step Müh. Yapi Ltd.

Barbaros Mah. · Kayacan Sokak No. 10
TR-34746 Yenisahra-Atasehir-Istanbul
☎ +90 216 4700-070, Fax -525 · E-Mail: info@stepyapi.com.tr

The Program for Comfort Air Technology

Key components

Air diffusers for ceilings, walls and floors: LTG System clean[®], linear diffusers, displacement air diffusers, swirl diffusers Coandavent[®] · LTG chilled beam cool wave[®] · Induction units Klima-vent[®] · Induction unit Coandatrol[®] · Fan coil units Raumluft · Ceiling fan coil units Ventotel[®] · Decentralized facade ventilation units Univent[®] · Airflow control units · labair[®] system: components for lab ventilation

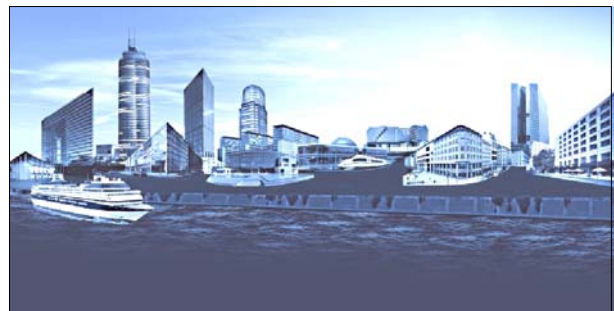

LTG Engineering Services

Technical services for investors, architects, engineers and plant builders during design, construction and operation of buildings. Reliable and precise data relating to the ventilation of air conditioning system are given already before realization of the project, determined by measurements, calculations, building simulations and experiments.

The Program for Process Air Technology

Key components

Axial, radial and tangential fans · Fahrtwind Simulators · LTG Filtration Technology: fans, suction nozzles, dampers, filters, separators, compactors · LTG Humidification Technology: air humidifiers, product humidifiers

LTG Engineering Services

Technical services during development and operation of assembly groups, machines and plants · Analysis, simulation, optimization · Customized solutions · Mobile filtration lab/ filter engineering on site